

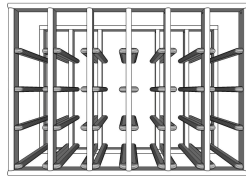

24 Bottle Curved Wine Rack

INSTRUCTIONS TO MODIFY A 24 BOTTLE RACK MODULE



Our wine racks are easily modified with basic hand tools.

You will require the following tools:

Pencil, Ruler, Square and Saw.

The modules can be shortened by **110mm** increments while leaving the style structure intact.

The complete module is 675mm long, this can be shortened to 565mm, 455mm etc

- 1) Lay the 2 top and 2 bottom bars on a flat surface, ensuring that they are evenly aligned.
- 2) Measure back from one end the distance that you wish to remove. I.e 110mm or 220mm etc. Rule a pencil line across all four pieces.

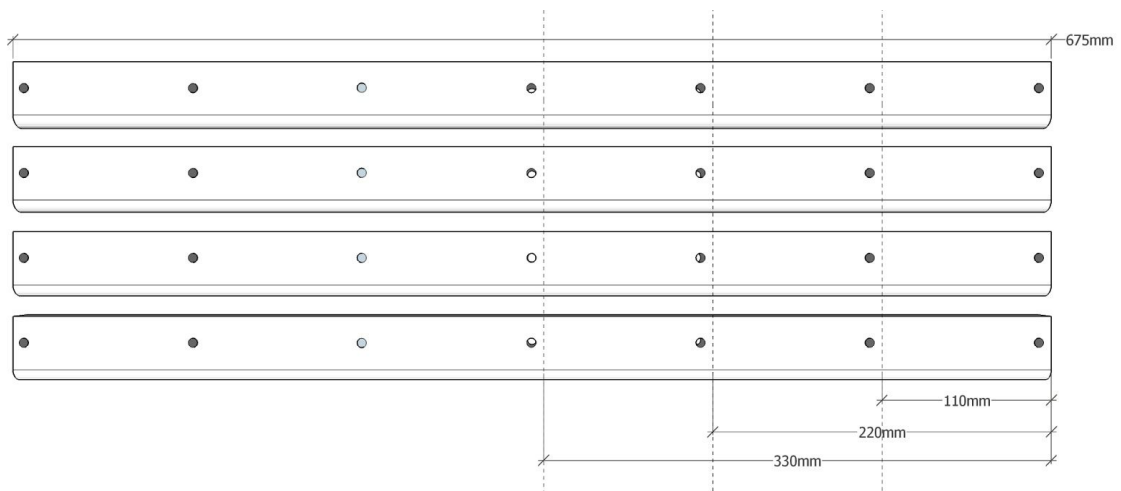

- 3) Cut the four bars at the length designated.

4) Assemble the rack as per the standard instruction.

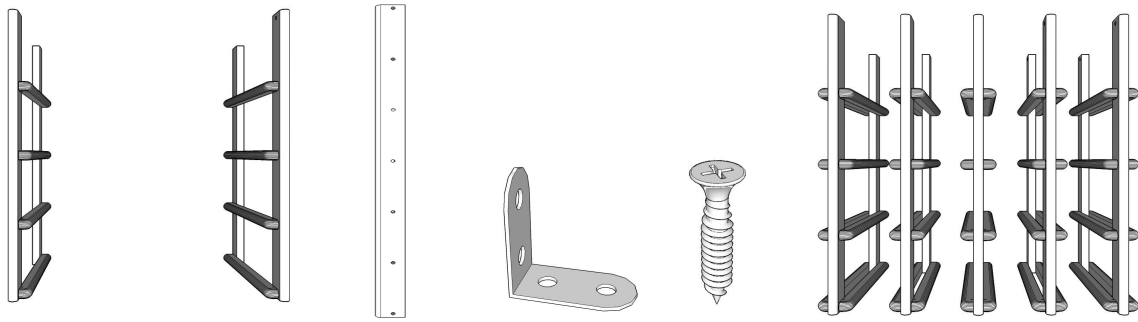

L' Column x1. R' Column x1 Bars x4 Wall Brackets x2 Screw x28 Centre Column x5

Tools required - Hand screw driver only. (wood will split with too much force from power drills)

- 1.) Arrange Bars for top and bottom with side Columns. Screw flush into pre drilled holes.
 - a.) Bars to have Countersunk face outside.
 - b.) Curved end of wine bottle fingers to the front.
 - c.) Wine bottle finger at bottom of Column.

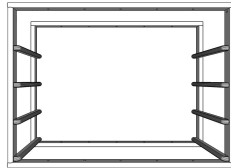

- 2.) Place Remaining Columns within the box. Screw flush into pre drilled holes top & bottom
 - a.) Curved end of wine bottle fingers to the front.
 - b.) Wine bottle finger at bottom of Column.

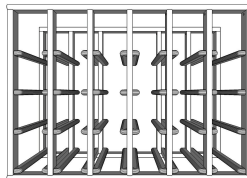

Thank you for purchasing this 24 Bottle Curved fingered Wine Rack
See install instruction over and always secure your wine rack to the wall.

See the build video at

<https://cellarsmart.com.au/product/wooden-wine-rack-24-bottle-storage-australian-cellar-design-timber/>